

HERZ Ball Valve with hose spout and lever

Datasheet
2510
Issue 0908

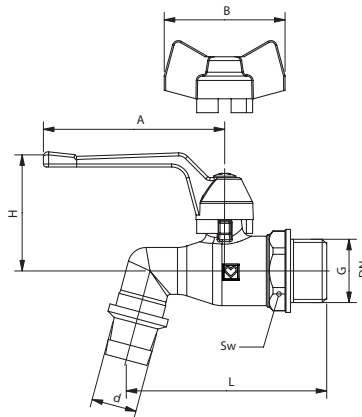

Model	Dim.	PN	DN	G	d	L	H	A	Sw
1 2510 00	3/8"	16	8	3/8"	12	57	38	60	21
1 2510 01	1/2"	16	10	1/2"	15	66	40	60	24

Model	Dim.	PN	DN	G	d	L	H	B	Sw
1 2510 10	3/8"	16	8	3/8"	12	57	38	40	21
1 2510 11	1/2"	16	10	1/2"	15	66	40	40	24

Dimensions

Body:	forged brass acc. EN 12420, nickel plated
End connection:	forged brass, nickel plated
Ball:	pressed brass, machined to a microsmooth finish, chrome plated
Spindle:	brass
Handle:	Aluminium alloy, red dipped
Spout hose connector:	brass, nickel plated
Sealing elements:	PTFE- polytetrafluoretylen (ball) and NBR 70 ShA (spindle)
Connections:	male thread acc. ISO228

Design

Working pressure:	up to 16 bar
Working temperature:	0°C to 90°C (water 0.5°C - 90°C, no steam)
Mediums:	water, air, oil, ... (non-aggressive mediums)

Operating data

The ball valve is used in installations as shut off valve. For use in the central heating systems, energy systems, construction engineering and mechanical engineering. Generally can be used with all non aggressive fluids such as hot water, wash liquids, dry compressed air. For use where one expects durability even if the working conditions are exceeded.

Application

We reserve the right to make modifications necessitated by technical progress.

Herz recommend the use of spinning material, teflon ribbon-sealing paste to seal the connection between the pipe and ball valve. Screw the ball valve into the pipe end with a suitable assembly tool (Sw) do not exceed the maximum torque. We recommend the valve in used in the index position, not in a mid position. The ball valve does't need special maintenance. At least twice per year exercise the valve.

Assembly and maintenance

All details contained in this brochure appertain to that available at the time of printing and serve as information. We reserve the right to make changes in the event of technical advancements. The illustrations are understood to be symbolic representations and may therefore vary visually from the actual products. Any colour variations are dependent upon the printing technology used. Products may also vary according to the country. We reserve the right to make changes to technical specifications and functions. Please contact your nearest branch of HERZ with any questions.